

# Hydraulic hoisting winches

Serie A / Model A150-5

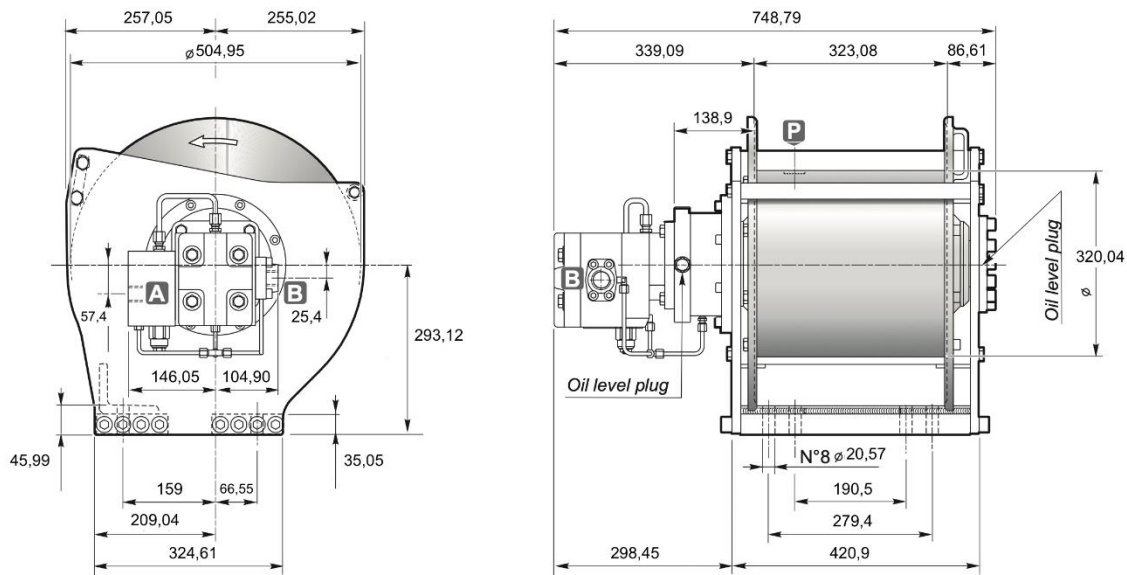

## DIMENSIONS (mm)



## TECHNICAL DATA

Rope layer		1	2	3	4	5	6
Line pull	daN	6672	6094	5604	5204	4848	4537
Rope speed with 170l/mn	m / mn	31.3	34.4	37.4	40.5	43.5	46.6
Rope speed with 302.8l/min	m/min	56.3	61.5	67	72.2	77.7	82.9

Hoisting pressure	max/min pump flow	Motor displacement	Gear ratio	Advised rope diameter	Weight	Connections A&B
bar	l/mn	cm3	1 :	mm	kg	
175		84	62.7		331.12	1" 5/16-12 THD SAE – 16 ORB

## OPTIONS

- CE standard kit