

Hydraulic hoisting winches

Serie A / Model A44

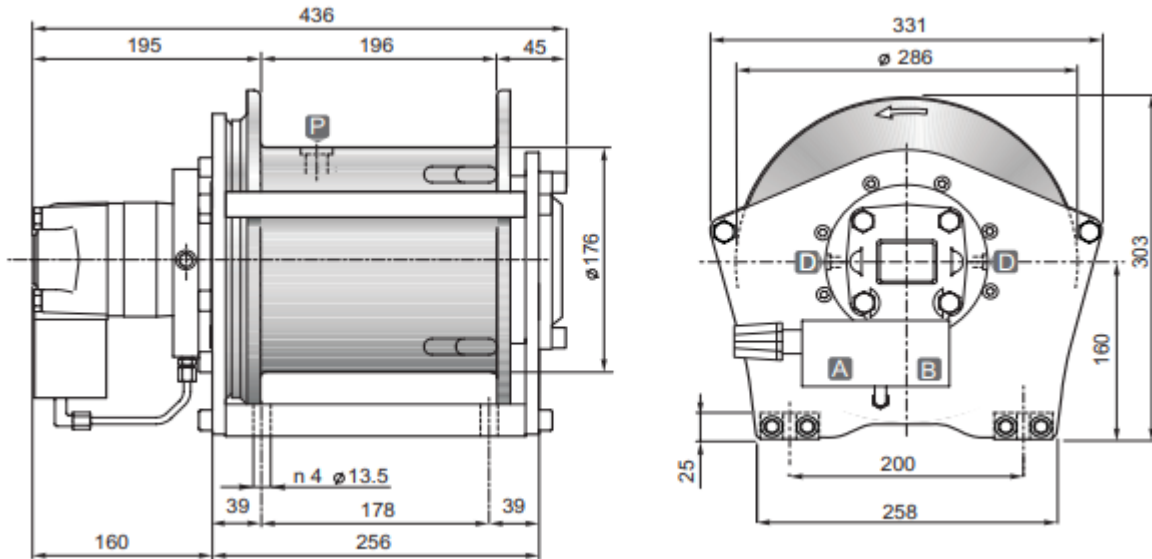

DIMENSIONS (mm)



TECHNICAL DATA

Rope layer		1	2	3	4
Line pull	<i>daN</i>	2000	1800	1650	1530
Rope speed with 76l/mn	<i>m / mn</i>	43	47.5	52	56.5
Rope capacity smooth drum	<i>m</i>	11	23	36	51

Hoisting pressure	max/min pump flow	Motor displacement	Gear ratio	Advised rope diameter	Weight	Connections A&B
<i>bar</i>	<i>l/mn</i>	<i>cm³</i>	<i>1 :</i>	<i>mm</i>	<i>kg</i>	
170	76/20	200	4.77	10	45	3/4"

OPTIONS

- CE standard kit