

Hydraulic hoisting winches

Serie A / Model A60

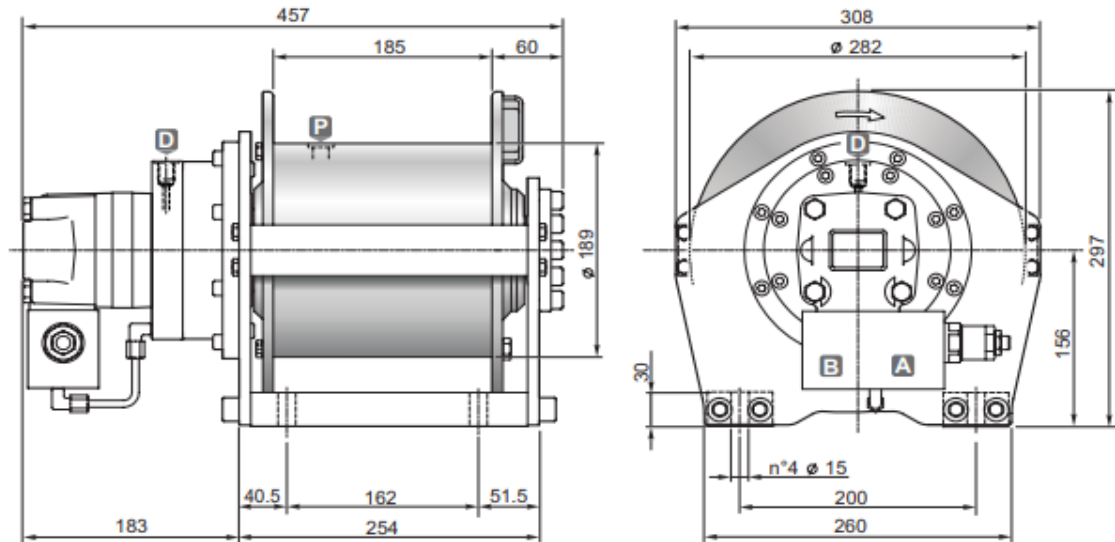

DIMENSIONS (mm)



TECHNICAL DATA

Rope layer		1	2	3	4
Line pull	daN	2670	2400	2180	2000
Rope speed with 64l/mn	m / mn	31.5	35	38.5	42
Rope capacity smooth drum	m	10	21	33	46

Hoisting pressure	max/min pump flow	Motor displacement	Gear ratio	Advised rope diameter	Weight	Connections A&B
bar	l/mn	cm ³	1 :	mm	kg	
185	75/10	100	12.28	11	74	3/4"

OPTIONS

- CE standard kit