

Hydraulic hoisting winches

Serie A / Model A80

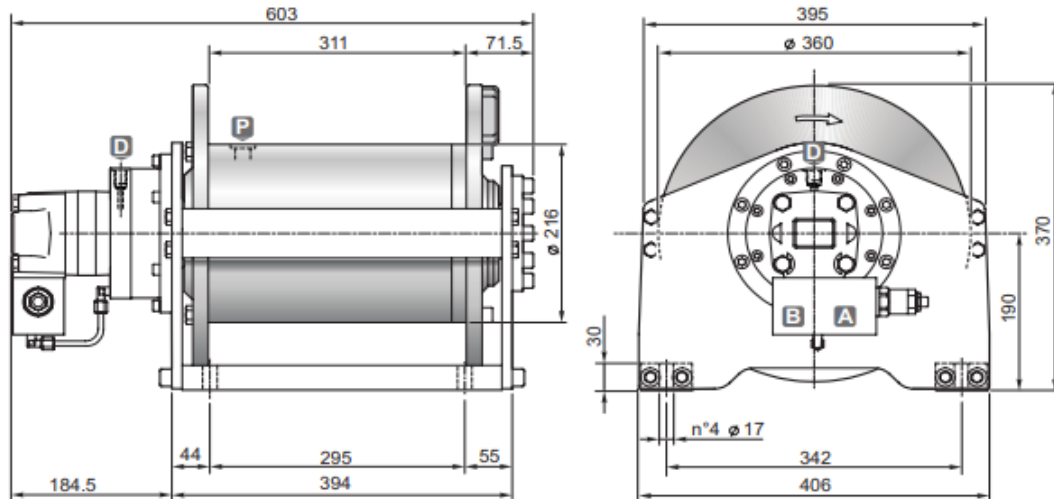

DIMENSIONS (mm)



TECHNICAL DATA

Rope layer		1	2	3	4
Line pull	daN	3525	3175	2885	2645
Rope speed with 45l/mn	m / mn	16	18	19.5	21.5
Rope capacity smooth drum	m	17	36	57	80

Hoisting pressure	max/min pump flow	Motor displacement	Gear ratio	Advised rope diameter	Weight	Connections A&B
bar	l/mn	cm ³	1 :	mm	kg	
175	75/6	125	15.3	12.7	132	3/4"

OPTIONS

- CE standard kit