

## Hydraulic hoisting winches

Serie CW / Model CW08

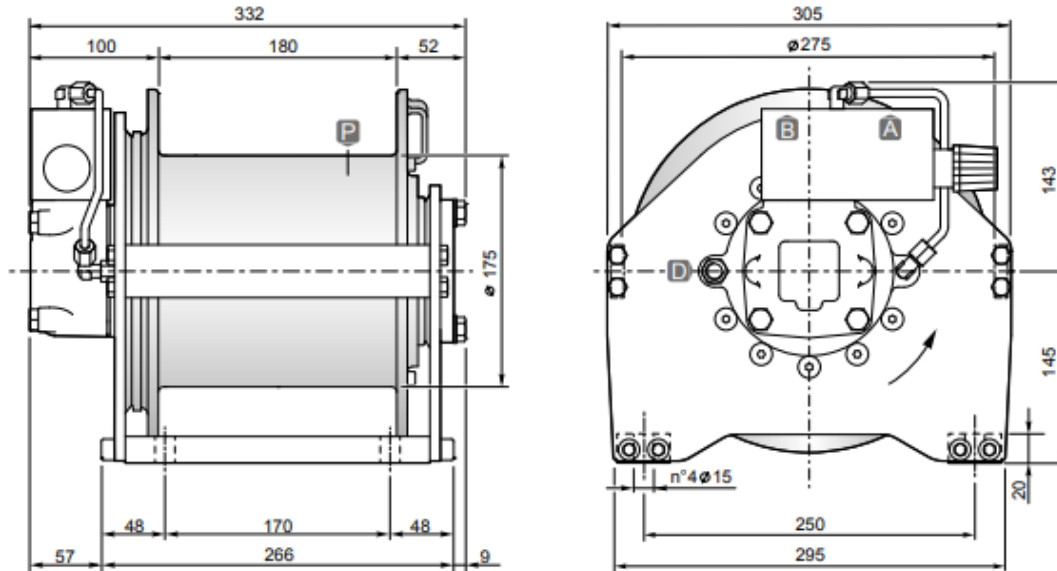

### DIMENSIONS (mm)



### TECHNICAL DATA

Rope layer		1	2	3	4
Line pull	daN	1010	930	860	800
Rope speed with 40l/mn	m / mn	42	46	49	53
Rope capacity smooth drum	m	12	25	40	56

Hoisting pressure	max/min pump flow	Motor displacement	Gear ratio	Advised rope diameter	Weight	Connections A&B
bar	l/mn	cm <sup>3</sup>	1 :	mm	kg	
170	60/15	100	4.77	8	45	3/4"

### OPTIONS

- Cable tensioner
- Cable tensioner and lowering rope end micro switch
- Cable tensioner and hydraulic lowering end stroke
- Electronic load detection system
- Electric rotary limit switch
- CE standard kit