

Hydraulic hoisting winches

Serie NP / Model NP 10

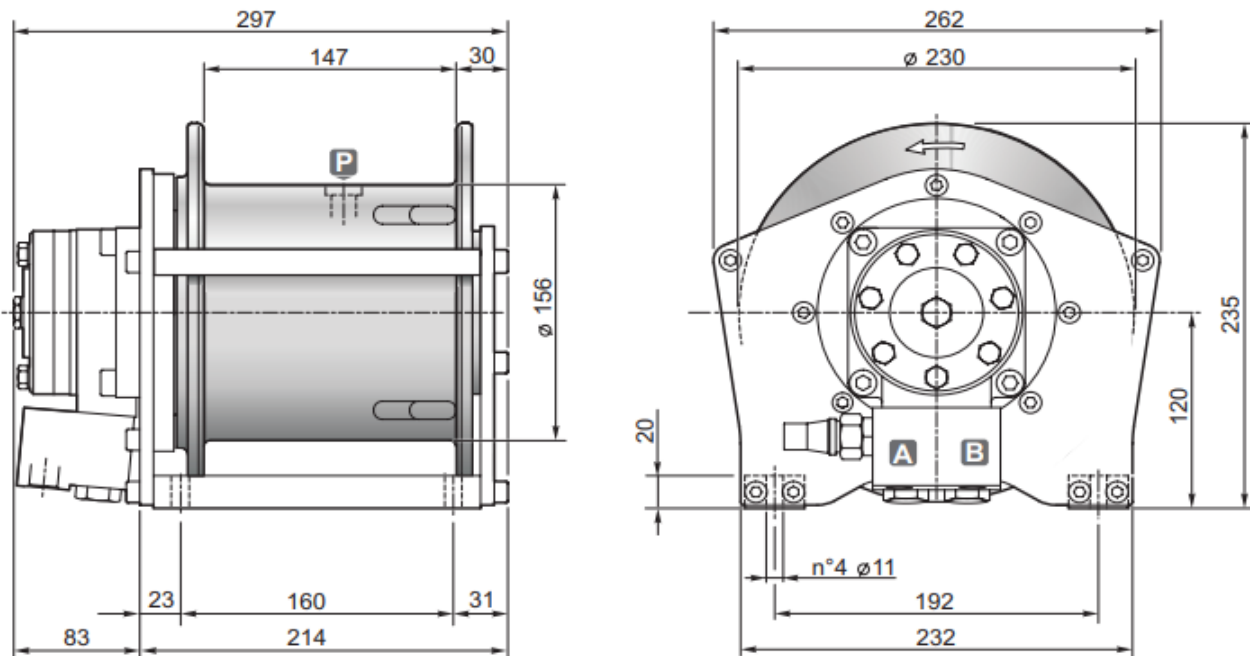

DIMENSIONS (mm)



TECHNICAL DATA

Hoisting pressure	max/min pump flow	Motor displacement	Gear ratio	Advised rope diameter	Weight	Connections A&B
<i>bar</i>	<i>l/mn</i>	<i>cm³</i>	<i>1 :</i>	<i>mm</i>	<i>kg</i>	
165	30/10	100	5.23	8	34	3/8"

Rope layer		1	2	3
Line pull	<i>daN</i>	1100	1000	920
Rope speed with 20l/mn	<i>m / mn</i>	16	17.5	19
Rope capacity smooth drum	<i>m</i>	9	19	30

OPTIONS

- Cable tensioner
- Cable tensioner and lowering rope end micro switch
- Cable tensioner and hydraulic lowering end stroke
- CE standard kit