

## Hydraulic hoisting winches

Serie NP / Model NP A18

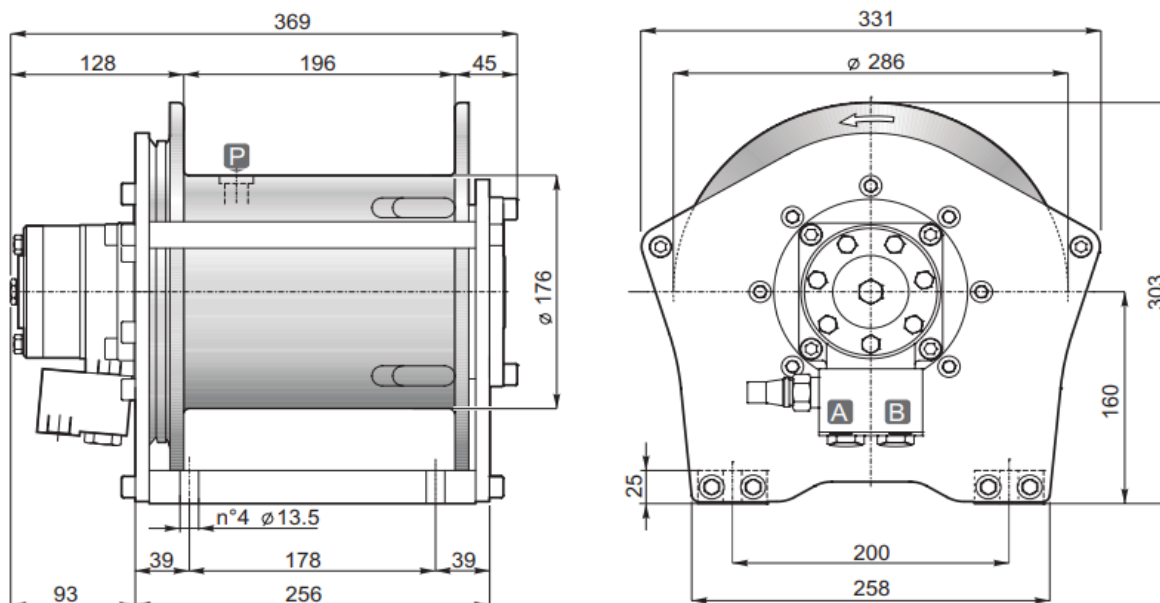

### DIMENSIONS (mm)



### TECHNICAL DATA

Hoisting pressure	max/min pump flow	Motor displacement	Gear ratio	Advised rope diameter	Weight	Connections A&B
<i>bar</i>	<i>l/mn</i>	<i>cm3</i>	<i>1 :</i>	<i>mm</i>	<i>kg</i>	
180	40/15	160	4.77	10	44	3/8"

Rope layer		1	2	3	4
Line pull	<i>daN</i>	1500	1350	1250	1130
Rope speed with 30l/mn	<i>m / mn</i>	19	21	23	25
Rope capacity smooth drum	<i>m</i>	11	23	36	51

### OPTIONS

- Cable tensioner
- Cable tensioner and lowering rope end micro switch
- Cable tensioner and hydraulic lowering end stroke
- CE standard kit