

Hydraulic hoisting winches

Serie P / Model P 15

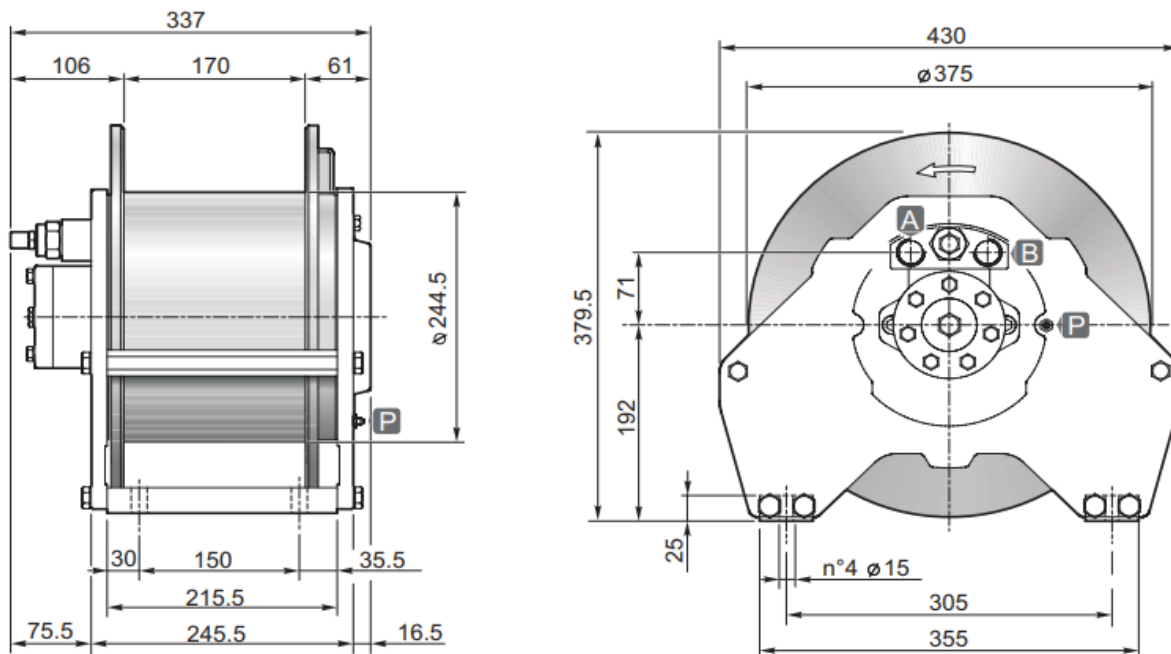

DIMENSIONS (mm)



TECHNICAL DATA

Hoisting pressure	max/min pump flow	Motor displacement	Gear ratio	Advised rope diameter	Weight	Connections A&B
<i>bar</i>	<i>l/mn</i>	<i>cm³</i>	<i>1 :</i>	<i>mm</i>	<i>kg</i>	
170	75/25	249	5.77	10	80	3/4"

Rope layer		1	2	3	4
Line pull	<i>daN</i>	2000	1850	1730	1600
Rope speed with 60l/mn	<i>m / mn</i>	30	32	34.5	37
Rope capacity smooth drum	<i>m</i>	13	26	41	57
Rope capacity grooved drum	<i>m</i>	12	24	37	51

OPTIONS

- Cable tensioner
- Cable tensioner and lowering rope end micro switch
- Cable tensioner and hydraulic lowering end stroke
- CE standard kit