

Hydraulic hoisting wiches

Serie P / Model P 15/E

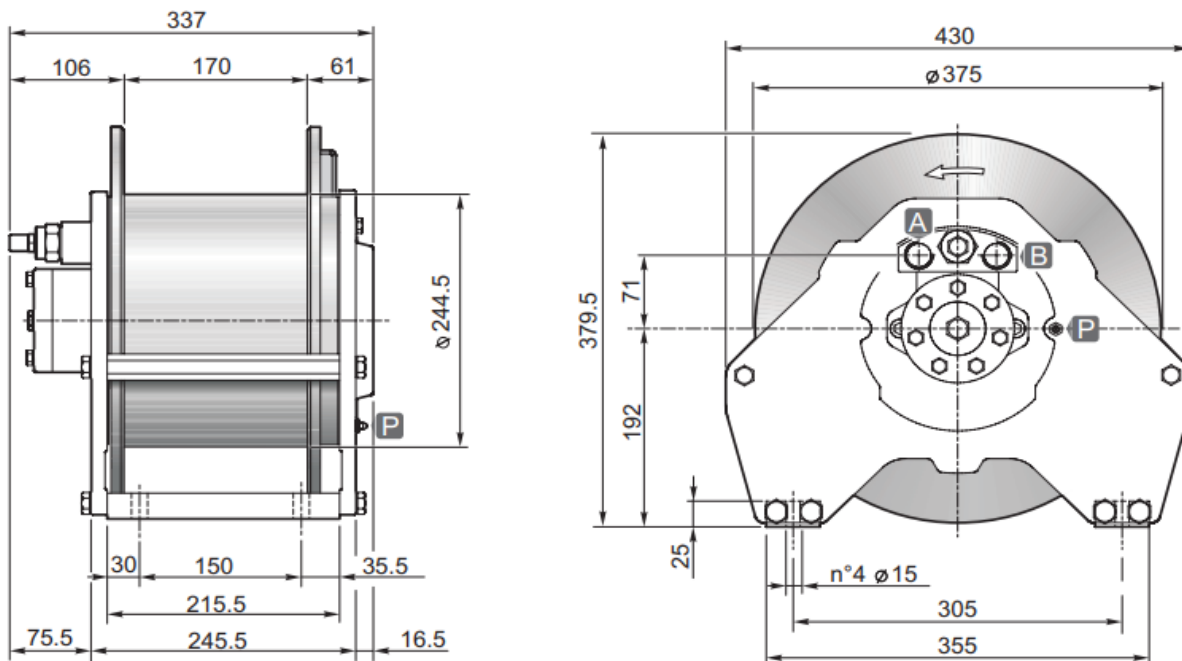

DIMENSIONS (mm)



TECHNICAL DATA

Hoisting pressure	max/min pump flow	Motor displacement	Gear ratio	Advised rope diameter	Weight	Connections A&B
<i>bar</i>	<i>l/mn</i>	<i>cm3</i>	<i>1 :</i>	<i>mm</i>	<i>kg</i>	
175	75/30	315	5.77	12	80	3/4"

Rope layer		1	2	3	4
Line pull	<i>daN</i>	2500	2300	2100	1950
Rope speed with 60l/mn	<i>m / mn</i>	24	26	28	30
Rope capacity smooth drum	<i>m</i>	11	22	34	48
Rope capacity grooved drum	<i>m</i>	10	21	33	46

OPTIONS

- Cable tensioner
- Cable tensioner and lowering rope end micro switch
- Cable tensioner and hydraulic lowering end stroke
- CE standard kit