

Hydraulic hoisting winches

Serie P / Model P 9

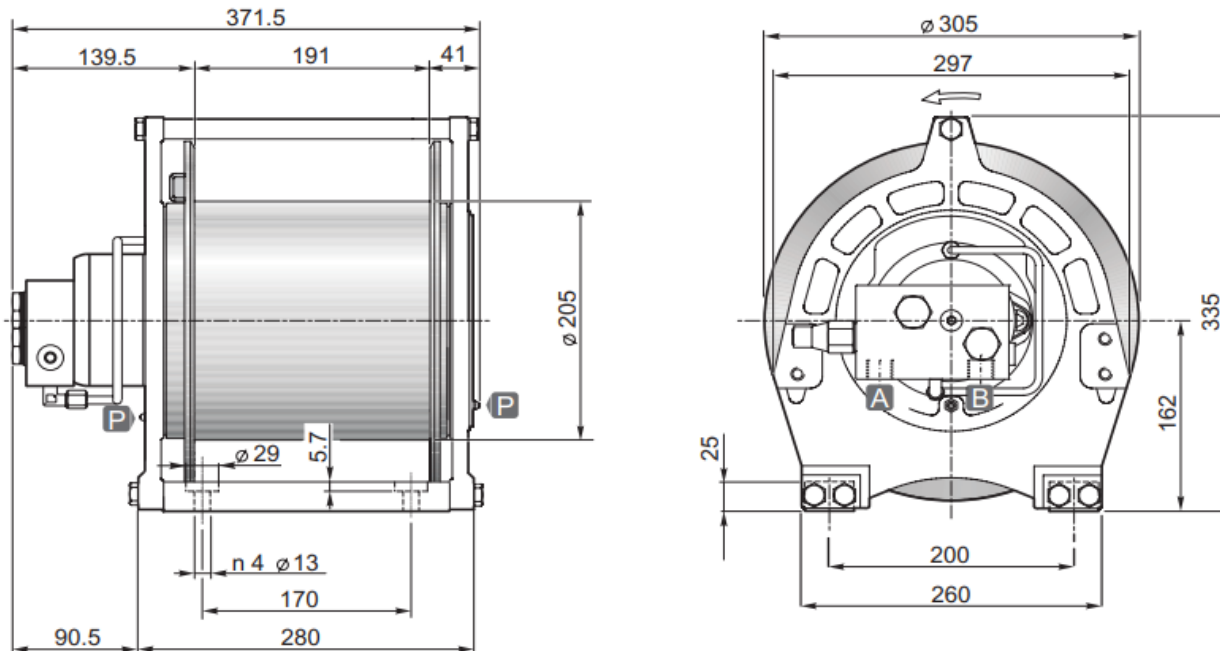

DIMENSIONS (mm)



TECHNICAL DATA

Hoisting pressure	max/min pump flow	Motor displacement	Gear ratio	Advised rope diameter	Weight	Connections A&B
<i>bar</i>	<i>l/mn</i>	<i>cm³</i>	1 :	<i>mm</i>	<i>kg</i>	
145	55/15	160	5.04	8	54	1/2"

Rope layer		1	2	3	4
Line pull	<i>daN</i>	1100	1000	950	900
Rope speed with 40l/mn	<i>m / mn</i>	27.5	29.5	31.5	34
Rope capacity smooth drum	<i>m</i>	15	31	49	68
Rope capacity grooved drum	<i>m</i>	13	28	44	60

OPTIONS

- Cable tensioner
- Cable tensioner and lowering rope end micro switch
- Cable tensioner and hydraulic lowering end stroke
- CE standard kit