

Hydraulic hoisting winches

Serie P / Model P 6/E

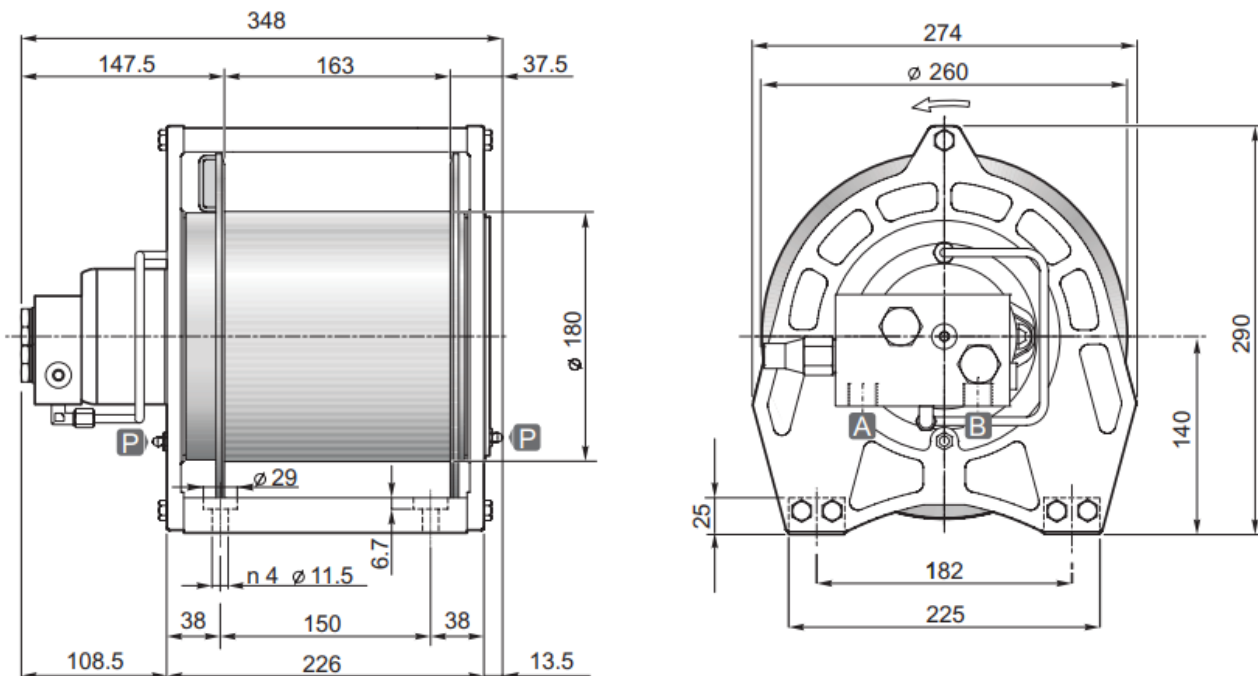

DIMENSIONS (mm)



TECHNICAL DATA

Hoisting pressure	max/min pump flow	Motor displacement	Gear ratio	Advised rope diameter	Weight	Connections A&B
<i>bar</i>	<i>l/mn</i>	<i>cm³</i>	<i>1 :</i>	<i>mm</i>	<i>kg</i>	
100	40/10	160	6	8	33	1/2"

Rope layer		1	2	3	4
Line pull	<i>daN</i>	1000	920	850	800
Rope speed with 20l/mn	<i>m / mn</i>	20	21.5	23.5	25
Rope capacity smooth drum	<i>m</i>	11	23	36	50
Rope capacity grooved drum	<i>m</i>	10	21	32	44

OPTIONS

- Cable tensioner
- Cable tensioner and lowering rope end micro switch
- Cable tensioner and hydraulic lowering end stroke
- CE standard kit