

# Hydraulic hoisting winches

Serie S / Model S 45V/2

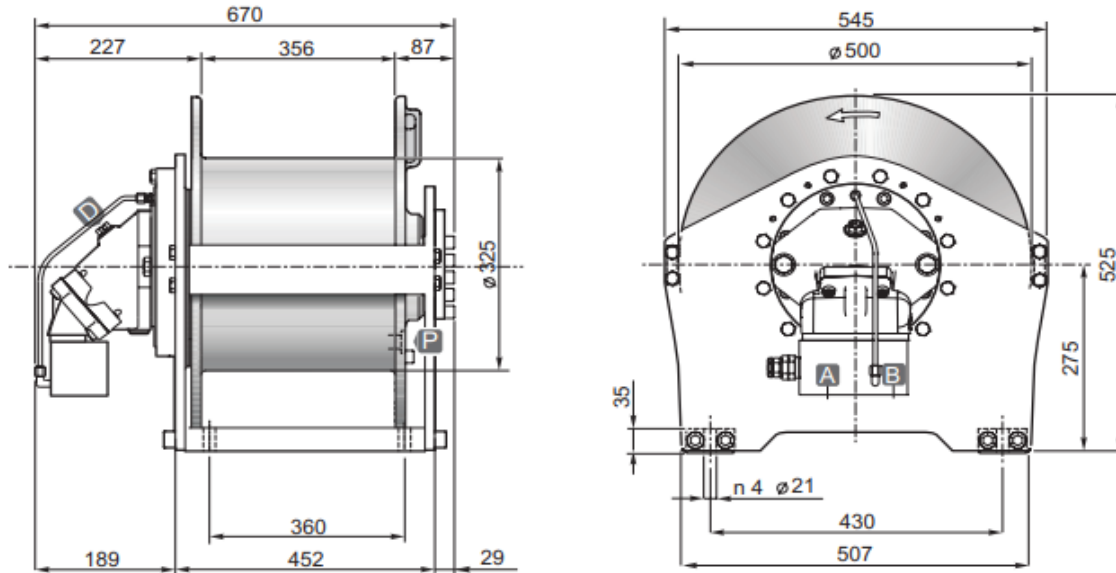

## DIMENSIONS (mm)



## TECHNICAL DATA

Hoisting pressure	max/min pump flow	Motor displacement	Gear ratio	Advised rope diameter	Weight	Connections A&B
<i>bar</i>	<i>l/mn</i>	<i>cm<sup>3</sup></i>	<i>1 :</i>	<i>mm</i>	<i>kg</i>	
255	190/25	64	51.7	16	285	1"

Rope layer		1	2	3	4
Line pull	<i>daN</i>	5750	5250	4850	4500
Rope speed with 160l/mn	<i>m / mn</i>	48	53	58	63
Rope capacity smooth drum	<i>m</i>	23	47	74	103
Rope capacity grooved drum	<i>m</i>	21	43	68	94

## OPTIONS

- Cable tensioner
- Cable tensioner and lowering rope end micro switch
- Cable tensioner and hydraulic lowering end stroke
- Electric rotary limit switch
- CE standard kit