

Hydraulic hoisting winches

Serie SE / Model SE 25/3 V

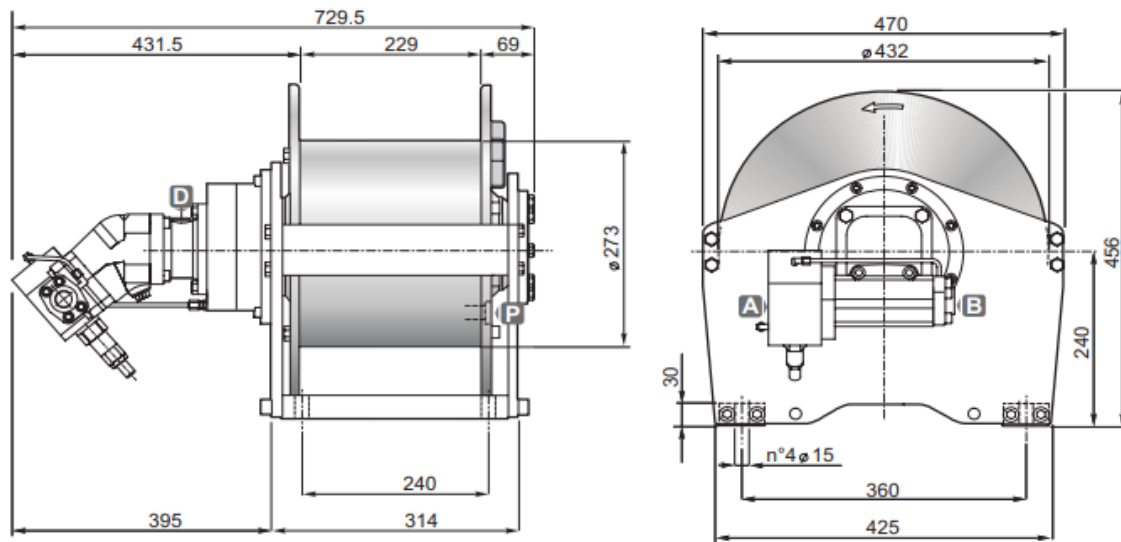

DIMENSIONS (mm)



TECHNICAL DATA

Hoisting pressure	max/min pump flow	Motor displacement	Gear ratio	Advised rope diameter	Weight	Connections A&B
<i>bar</i>	<i>l/mn</i>	<i>cm3</i>	<i>1 :</i>	<i>mm</i>	<i>kg</i>	
235	100/15	47	34.77	14	172	3/4"

Rope layer		1	2	3	4
Line pull	<i>daN</i>	3200	2950	2700	2500
Rope speed with 125l/mn	<i>m / mn</i>	64	70	76	82
Rope capacity smooth drum	<i>m</i>	14	29	45	63
Rope capacity grooved drum	<i>m</i>	13	27	42	59

OPTIONS

- Cable tensioner
- Cable tensioner and lowering rope end micro switch
- Cable tensioner and hydraulic lowering end stroke
- Electric rotary limit switch
- CE standard kit