

Hydraulic hoisting winches

Serie SE / Model SE 35 V

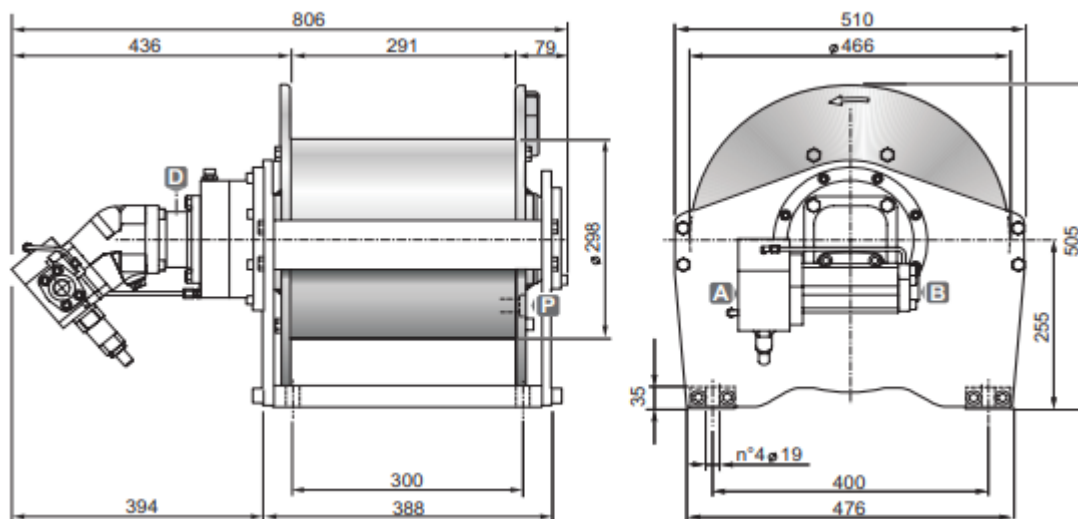

DIMENSIONS (mm)



TECHNICAL DATA

Hoisting pressure	max/min pump flow	Motor displacement	Gear ratio	Advised rope diameter	Weight	Connections A&B
<i>bar</i>	<i>l/mn</i>	<i>cm3</i>	1 :	<i>mm</i>	<i>kg</i>	
235	190/25	56	50.5	15	236	3/4" B ; 1" A

Rope layer		1	2	3	4
Line pull	<i>daN</i>	4500	4100	3800	3500
Rope speed with 80l/mn	<i>m / mn</i>	59	64	70	75
Rope capacity smooth drum	<i>m</i>	18	38	60	83
Rope capacity grooved drum	<i>m</i>	16	35	54	75

OPTIONS

- Cable tensioner
- Cable tensioner and lowering rope end micro switch
- Cable tensioner and hydraulic lowering end stroke
- Electric rotary limit switch
- CE standard kit