

Hydraulic hoisting winches

Serie SE / Model SE 45 V

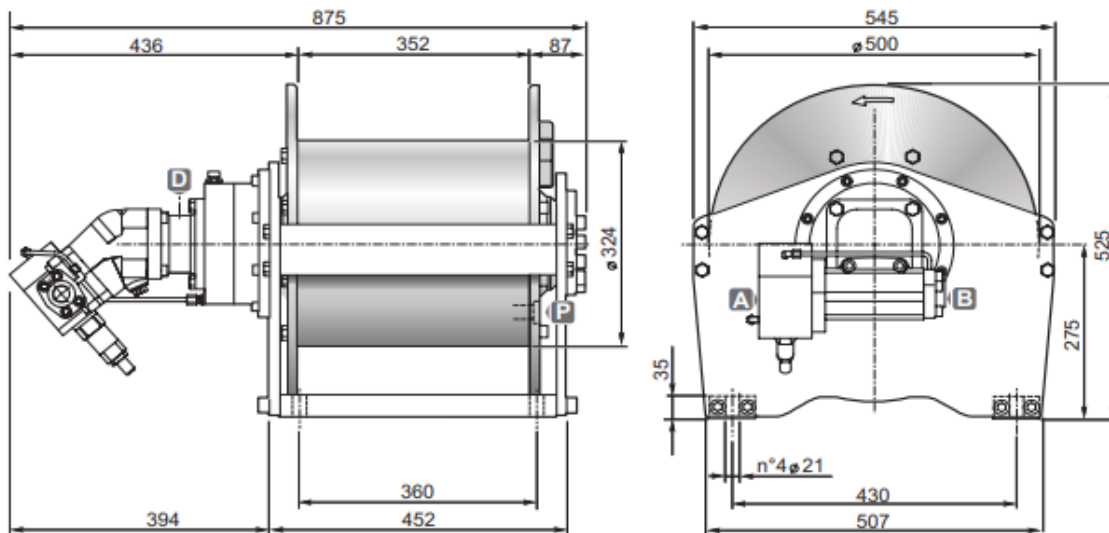

DIMENSIONS (mm)



TECHNICAL DATA

Hoisting pressure	max/min pump flow	Motor displacement	Gear ratio	Advised rope diameter	Weight	Connections A&B
<i>bar</i>	<i>l/mn</i>	<i>cm³</i>	<i>1 :</i>	<i>mm</i>	<i>kg</i>	
260	190/25	64	51.6	16	290	3/4" B ; 1" A

Rope layer		1	2	3	4
Line pull	<i>daN</i>	5770	5270	4860	4500
Rope speed with 180l/mn	<i>m / mn</i>	54.5	59.5	65	70
Rope capacity smooth drum	<i>m</i>	23	47	74	103
Rope capacity grooved drum	<i>m</i>	21	43	68	94

OPTIONS

- Cable tensioner
- Cable tensioner and lowering rope end micro switch
- Cable tensioner and hydraulic lowering end stroke
- Electric rotary limit switch
- CE standard kit