

Hydraulic hoisting winches

Serie SRD / Model SRD B80

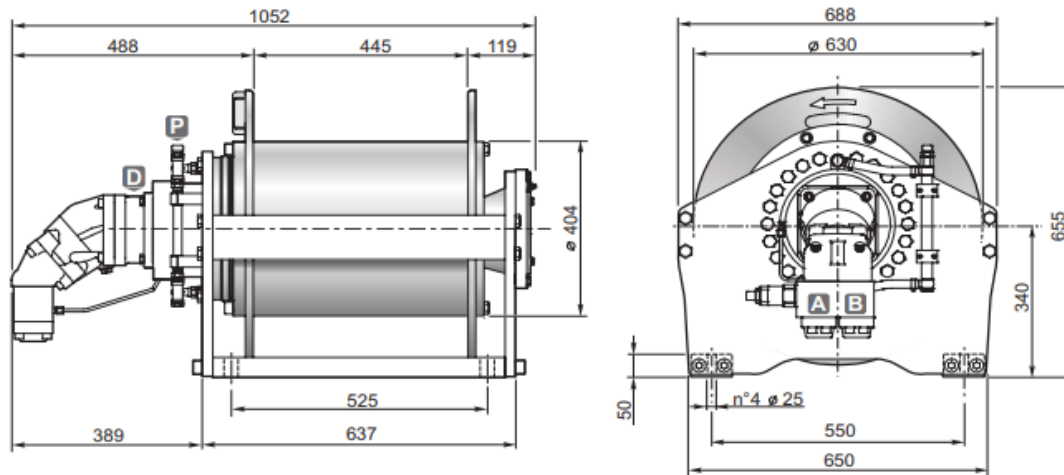

DIMENSIONS (mm)



TECHNICAL DATA

Hoisting pressure	max/min pump flow	Motor displacement	Gear ratio	Advised rope diameter	Weight	Connections A&B
<i>bar</i>	<i>l/mn</i>	<i>cm³</i>	<i>1 :</i>	<i>mm</i>	<i>kg</i>	
285	220/30	84	76.73	20	605	1"

Rope layer		1	2	3	4
Line pull	<i>daN</i>	10300	9400	8600	8000
Rope speed with 180l/mn	<i>m / mn</i>	35	38	42	45
Rope capacity smooth drum	<i>m</i>	28	59	93	129
Rope capacity grooved drum	<i>m</i>	26	56	88	123

OPTIONS

- Cable tensioner
- Cable tensioner and lowering rope end micro switch
- Cable tensioner and hydraulic lowering end stroke
- Electric rotary limit switch
- Hydraulic rotary limit switch
- CE standard kit