

## Hydraulic hoisting winches

Serie SRD / Model SRD C100

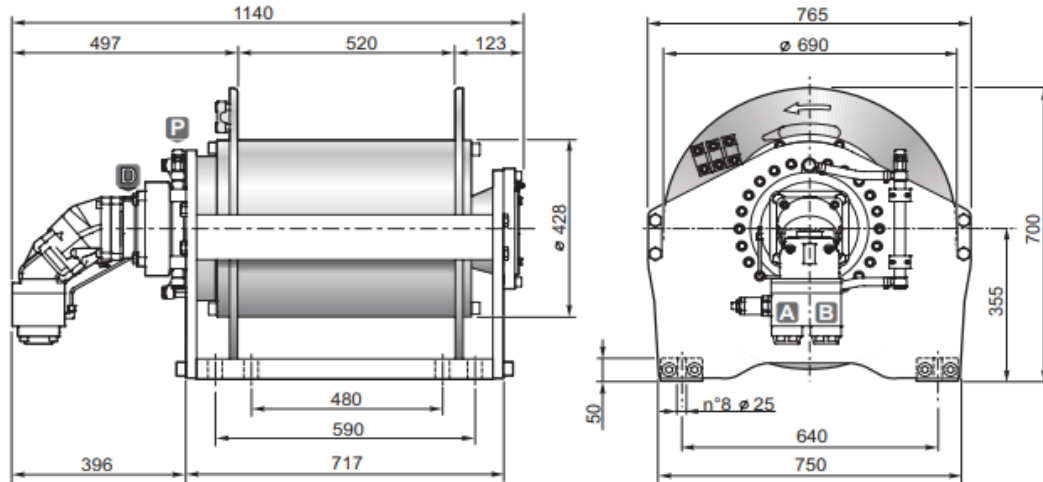

### DIMENSIONS (mm)



### TECHNICAL DATA

Hoisting pressure	max/min pump flow	Motor displacement	Gear ratio	Advised rope diameter	Weight	Connections A&B
<i>bar</i>	<i>l/mn</i>	<i>cm3</i>	<i>1 :</i>	<i>mm</i>	<i>kg</i>	
275	260/30	108	83.92	22	722	1"

Rope layer		1	2	3	4
Line pull	<i>daN</i>	13000	11800	10800	10000
Rope speed with 180l/mn	<i>m / mn</i>	32	36	39	42
Rope capacity smooth drum	<i>m</i>	32	67	105	147
Rope capacity grooved drum	<i>m</i>	30	63	100	140

### OPTIONS

- Cable tensioner
- Cable tensioner and lowering rope end micro switch
- Cable tensioner and hydraulic lowering end stroke
- Electric rotary limit switch
- Hydraulic rotary limit switch
- CE standard kit