

Hydraulic hoisting winches

Serie SRD / Model SRD D120

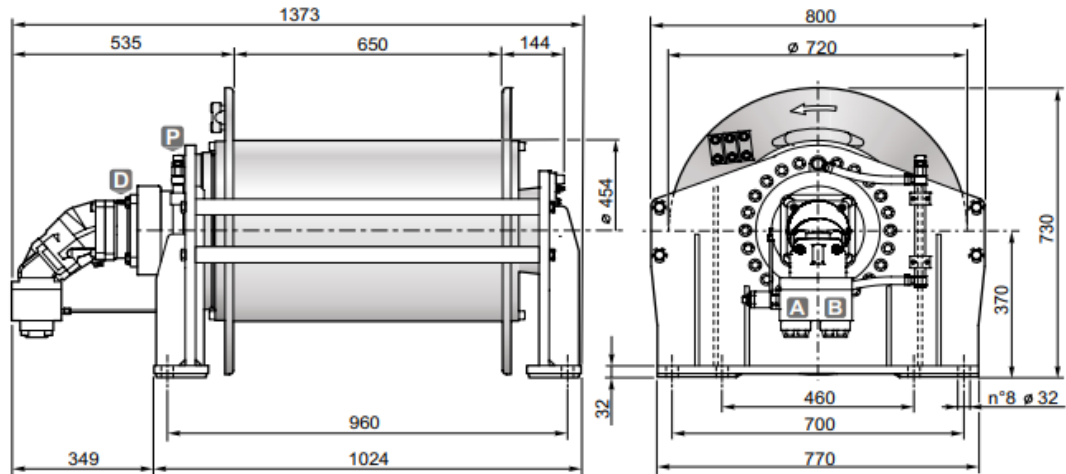

DIMENSIONS (mm)



TECHNICAL DATA

Hoisting pressure	max/min pump flow	Motor displacement	Gear ratio	Advised rope diameter	Weight	Connections A&B
<i>bar</i>	<i>l/mn</i>	<i>cm3</i>	1 :	<i>mm</i>	<i>kg</i>	
285	250/30	108	102.02	24	762	1"

Rope layer		1	2	3	4
Line pull	<i>daN</i>	15600	14200	13000	12000
Rope speed with 230l/mn	<i>m / mn</i>	29.5	32.5	35	38
Rope capacity smooth drum	<i>m</i>	39	82	129	180
Rope capacity grooved drum	<i>m</i>	35	77	123	173

OPTIONS

- Cable tensioner
- Cable tensioner and lowering rope end micro switch
- Cable tensioner and hydraulic lowering end stroke
- Electric rotary limit switch
- Hydraulic rotary limit switch
- CE standard kit