

Hydraulic hoisting winches

Serie SRD / Model SRD E150

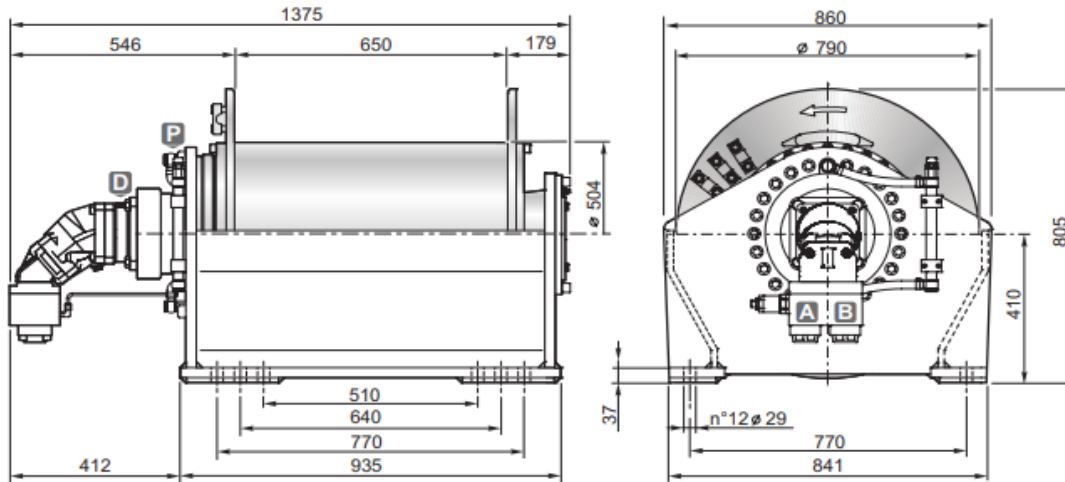

DIMENSIONS (mm)



TECHNICAL DATA

Hoisting pressure	max/min pump flow	Motor displacement	Gear ratio	Advised rope diameter	Weight	Connections A&B
<i>bar</i>	<i>l/mn</i>	<i>cm3</i>	<i>1 :</i>	<i>mm</i>	<i>kg</i>	
290	250/30	130	117.8	26	762	1"

Rope layer		1	2	3	4
Line pull	<i>daN</i>	19400	17650	16200	15000
Rope speed with 250l/mn	<i>m / mn</i>	25.5	28	30.5	33
Rope capacity smooth drum	<i>m</i>	40	84	132	183
Rope capacity grooved drum	<i>m</i>	36	79	126	176

OPTIONS

- Cable tensioner
- Cable tensioner and lowering rope end micro switch
- Cable tensioner and hydraulic lowering end stroke
- Electric rotary limit switch
- Hydraulic rotary limit switch
- CE standard kit