

Hydraulic hoisting winches

Serie SRD / Model SRD F180

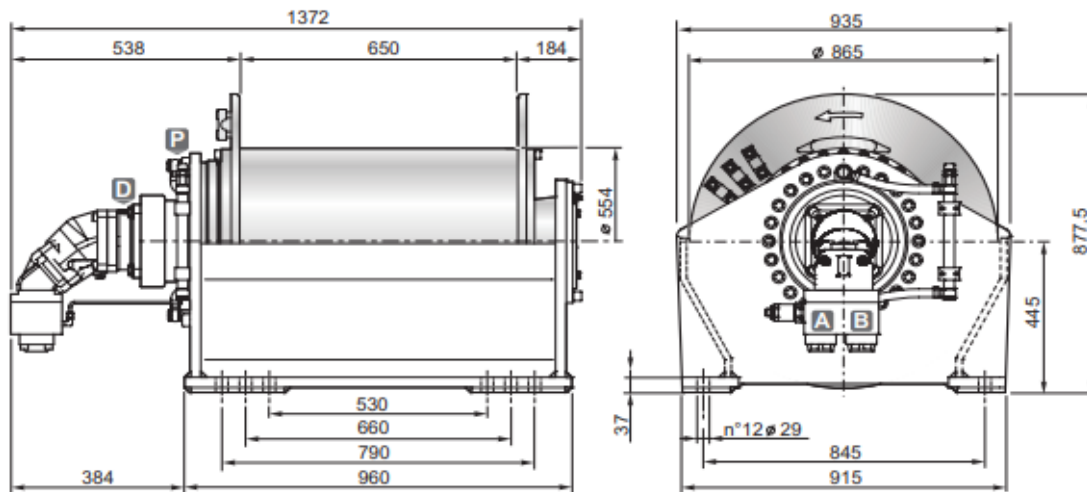

DIMENSIONS (mm)



TECHNICAL DATA

Hoisting pressure	max/min pump flow	Motor displacement	Gear ratio	Advised rope diameter	Weight	Connections A&B
<i>bar</i>	<i>l/mn</i>	<i>cm3</i>	<i>1 :</i>	<i>mm</i>	<i>kg</i>	
295	250/30	130	150.2	28	795	1"

Rope layer		1	2	3	4
Line pull	<i>daN</i>	23200	21150	19450	18000
Rope speed with 250l/mn	<i>m / mn</i>	22	24	26	28
Rope capacity smooth drum	<i>m</i>	40	85	133	186
Rope capacity grooved drum	<i>m</i>	37	80.5	128	179

OPTIONS

- Cable tensioner
- Cable tensioner and lowering rope end micro switch
- Cable tensioner and hydraulic lowering end stroke
- Electric rotary limit switch
- Hydraulic rotary limit switch
- CE standard kit