

# Hydraulic towing winch

## Serie T / Model T27 IN

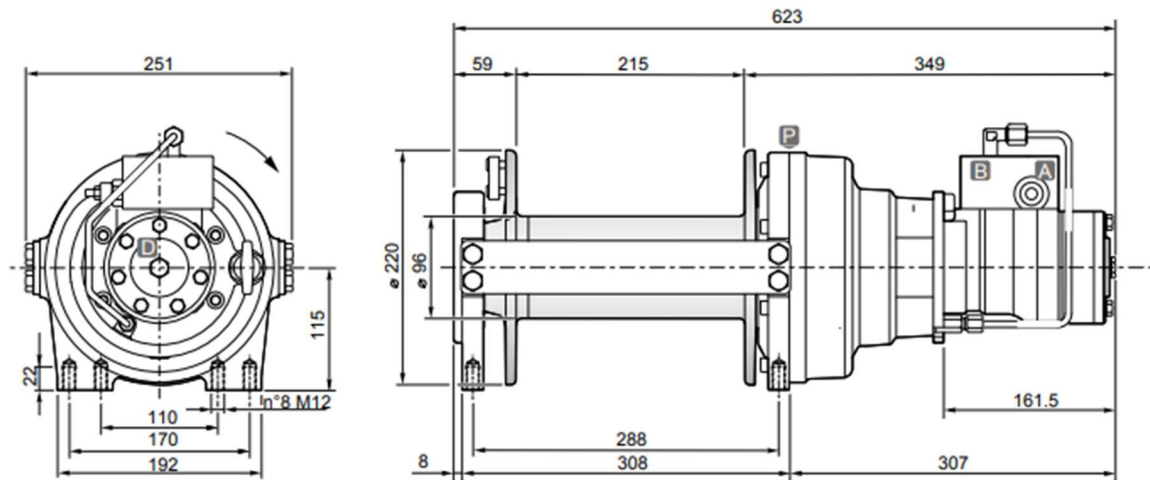

### DIMENSIONS (mm)



### TECHNICAL DATA

Rope layer		1	2	3	4
Line pull	daN	2700	2300	2000	1725
Rope speed with 40l/mn	m / mn	12	14	16	19
Rope capacity smooth drum	m	6.8	15	24	35

Hoisting pressure	max/min pump flow	Motor displacement	Gear ratio	Advised rope diameter	Weight	Connections A&B
bar	l/mn	cm <sup>3</sup>	1 :	mm	kg	
140	50/10	160	1 :5.77	10	50	1/2"

### OPTIONS

- Cable tensioner kit
- Cable guide kit